

dreamwalls

INNOVATIVE GLASS PRODUCTS



Glass & Mirror Products



Glass and mirrors that impress. Service you can rely on.

Glass and mirrors that inspire.

Interiors shouldn't be boring. Decorative glass and mirrors can help create stunningly beautiful and inspiring spaces that people love.

choose your **STYLE**

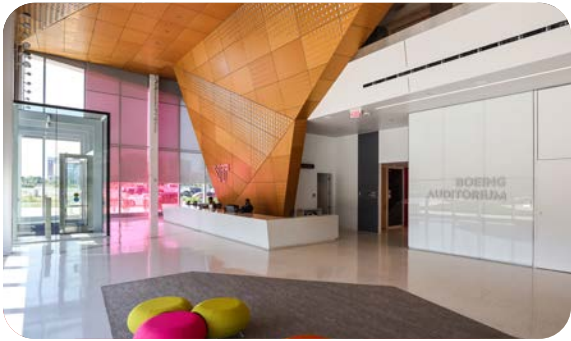

go **MODERN**

- Glass Markerboards page 3
- Tempered Glass page 6
- Shades Tinted Mirrors page 7
- Acid-Etched Mirrors page 8
- Sandblasted Mirrors page 9



go **CLASSY**

- Antique Mirrors page 10
- Standard Mirrors page 11
- Clarity Mirrors page 12



go **COLORFUL**

- Backpainted Glass page 13



go **ULTRA CUSTOM**

- Laminated Glass page 15
- Laminated Mirrors page 17
- Tempered Mirrors page 18

Why Dreamwalls?

At Dreamwalls, we strive to deliver innovative glass products that architects, designers, contractors, glaziers, and installers can build their business and reputation on. Our goal is to help you succeed with glass.

Experience

We've been manufacturing glass and mirrors since 1962, with over 1 billion sq ft delivered.

Quality

We stand behind our products and meticulously manufacture to spec and industry standards.

Committed Service

Our team works diligently to keep projects on schedule and quickly solve any challenges.

Design Customization

Unleash your creativity by customizing and combining a variety of Dreamwalls products.

Made in the USA

Support local business and jobs. Our manufacturing is proudly done in NC and TX.

Values Driven

Good values create happier employees and produce great results for customers.

Broad Capabilities

We offer a broad range of in-house fabrication, helping control quality and lead times.

Low Lead Times

Get orders delivered on time to keep projects on schedule with industry-leading lead times.

Competitive Pricing

Our experience, efficiency, and in-house capabilities often result in significant savings for our customers.

“The entire team, leadership, sales, customer support, manufacturing, and delivery has consistently been exceptional.”

Joey Karas, Karas & Karas Glass, Boston *(customer for over 30 years)*

Dreamwalls white backpainted glass at Honda of Indian Trail, NC

The Power of DreamS

Glass Markerboards

The premiere writing surface that looks fabulous for years and won't stain or ghost.

Heat Cured

Up to 144 x 94"



PRODUCT INFO

Glass: Made with the highest quality, super-clear low-iron glass for crisp white and vivid colors.

Size Options: 9 standard options or custom sizes on request.

	4'x4'	5'x4'	6'x4'	8'x4'	10'x4'
	4'x3'	5'x3'	6'x3'		
	3'x2'				

Finishes: Classic Glossy, ProSuede (matte, anti-glare finish), Metallic, or Pearlescent

Weight per SqFt: 4.8 lbs for magnetic, 3.2 lbs for non-magnetic

Edges: Flat Polished

Fabrication Options: Radius Corners, Holes, Cutouts, Notches

Safety Options: Tempering comes standard.

Max Size: 144" x 94"

Thickness: 6mm (1/4") unless requested otherwise

Quick Ship: 6' x 4' and 8' x 4' True White Magnetic Glass Markerboards can ship within 2-5 days.

Accessories: Optional kit includes markers, marker holder, magnets, and eraser. Shelf options also available.



Colors: Choose from 15 standard colors or match any color within 1 Delta E using a spectrophotometer.



Protective Coat: We paint a protective coat on top of the color to help protect the color layer from damage during transit and installation.

Backing Options



Hanging Methods



Warranty: 10 Years

Samples available on:



Specify on:



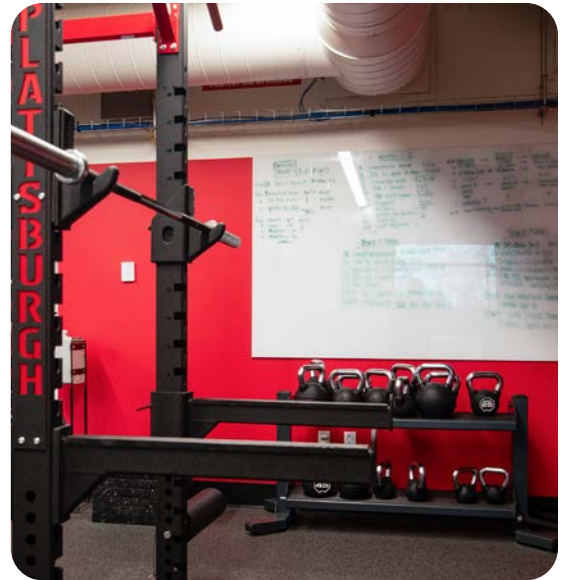

Markerboard Quick Ship

Get 6'x4' and 8'x4' True White magnetic glass markerboards shipped in 2-5 days!



6'x4' markerboard shown above

DETAILS

Glass: Made with the highest quality, super-clear low-iron glass for crisp white and vivid colors.

Size Options: 6'x4' or 8'x4'

	6'x4'	8'x4'
--	-------	-------

Finish: Classic Glossy

Weight per SqFt: 4.8lbs (magnetic)

Edges: Flat Polished

Safety: Tempered

Thickness: 6mm (1/4")

Accessories: Optional kit includes marker holder, magnets, and eraser. A 12" magnetic shelf is also available.



Color



True White

Backing



Magnetic
(galvanized steel)

Hanging Method



Invisible Z-clips
(included)



Tempered Glass

Four times stronger than non-tempered glass.



PRODUCT INFO

Glass: Choose from low-iron, clear, bronze, or gray glass.

Acid-Etch Options



Satinlite

Satin

Velour
(1 or 2 sides)

Opaque
(1 or 2 sides)

Edges: Clean Cut, Seamed, Flat Polished, or Pencil Polished

Fabrication Options: Holes, Cutouts, Notches

Min Size: 10" x 20"

Max Size: 94" x 144" (dependent on glass type; minimums apply for largest sizes)

Thickness: 5mm (3/16"), 6mm (1/4"), 8mm (5/16"), 10mm (3/8"), or 12mm (1/2")

Compliance: ASTM C1048, ANZI Z97.1, 16 CFR 1201 II (Federal Safety Standard)

Warranty: 5 Years



Specify on:



Shades Tinted Mirrors

Who says all mirrors need to look the same?
Make a statement.



Above: Blue Mirrors Below: Gray Mirrors

PRODUCT INFO

Color Options:

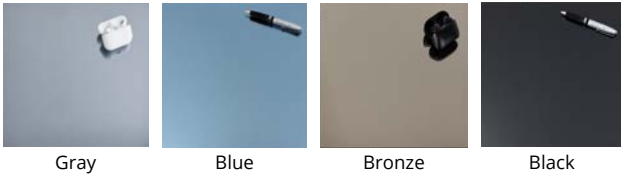

Edges: Clean Cut, Seamed, Flat Polished, or Pencil Polished

Fabrication Options: Holes, Cutouts, Notches

Safety Options: Tempering, Laminating

Max Size: 96" x 130"

Thickness: 6mm (1/4")

Warranty: 10 Years

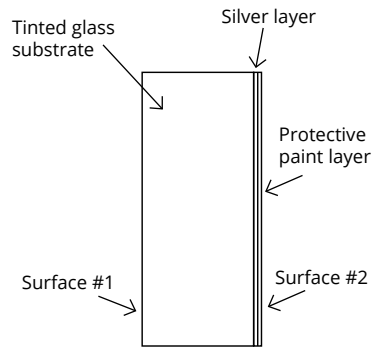

Order Samples on:
Material Bank

Specify on:
MasterSpec
RIB | SpecLink



Below: Black Mirror Right: Bronze Mirrors

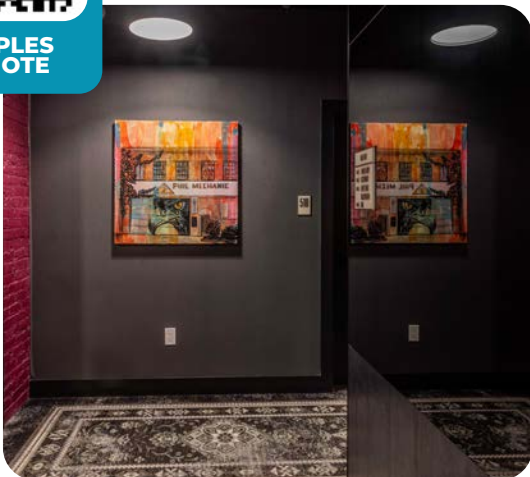

Acid-Etched Mirrors

For a modern look with a soft, matte finish and subtle reflections.



Above and Below: Gray and Low-Iron Etched Mirrors

PRODUCT INFO

Color Options

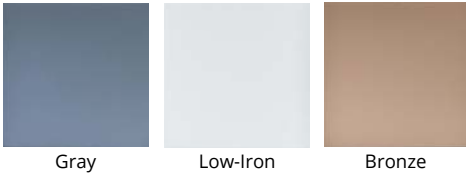

Gray

Low-Iron

Bronze

Acid-Etched Finish Options



Satin
(light reflection)

Velour
(matte finish with
slight reflection)

Opaque
(matte finish)

If no finish is specified, Velour will be used.

Edges: Clean Cut, Seamed, Flat Polished, or Pencil Polished

Fabrication Options: Holes, Cutouts, Notches

Safety Option: Laminated (can be laminated on the paint side)

Max Size: 100" x 144" for Velour, 96" x 130" for Satin and Opaque

Thickness: 6mm (1/4")

Warranty: 10 Years

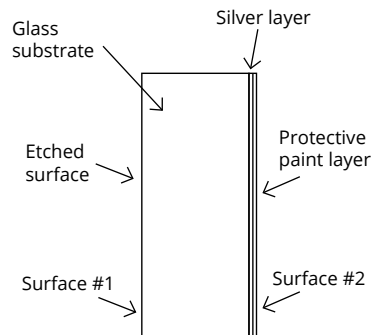

Order Samples on:



Specify on:



Below: Bronze Etched Mirrors Bottom Right: Low-Iron Etched Mirrors



Sandblasted Mirrors

Designed to please, these mirrors not only look magnificent, but they also help light their subjects like no other mirror can.



PRODUCT INFO

Glass: Made from low-iron or mirror-quality clear glass.

Sandblasted Area: Custom (2-sides, 4-sides, various widths)

Edges: Clean Cut, Seamed, Flat Polished, or Pencil Polished

Fabrication Options: Holes, Cutouts, Notches

Max Size: 60" x 120"

Thickness: 3mm (1/8") to 6mm (1/4") for low iron mirror, or 2.5mm (3/32") to 10mm (3/8") for standard/clear glass

Note: To create this cool effect, a portion of the mirror is taped off and sandblasted, creating a matte glass look in a portion of the mirror that can be lit from behind with LED lights.

Warranty: 5 Years

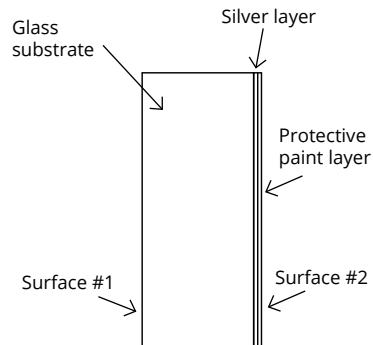

Specify on:
MasterSpec
RIB | SpecLink



Sandblasting is done on the back, stripping the reflective silver layer and creating a sandblasted, matte surface on Surface #2.

Antique Mirrors

Classy antique mirrors with beautifully consistent patterns.

Up to 84 x 130"



Above: Clear Charcoal Antique Mirrors

Below: Bronze Charcoal Antique Mirrors

PRODUCT INFO

Color & Pattern Options

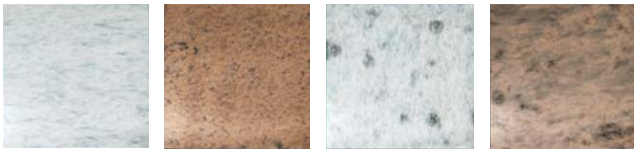

Clear Charcoal Bronze Charcoal Clear Storm Bronze Storm

Edges: Clean Cut, Seamed, Flat Polished, or Pencil Polished

Fabrication Options: Holes, Cutouts, Notches

Safety Options: Tempering, Laminating

Max Size: 84" x 130"

Thickness: 3mm (1/8") or 6mm (1/4")

Compliance: ASTM C1036 (annealed) or ASTM C1048 (tempered)

Warranty: 1 Year

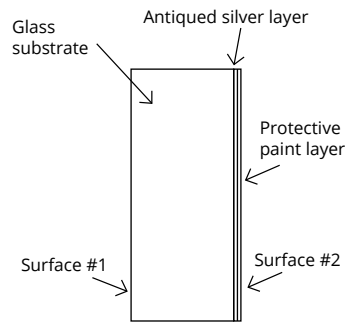

Order Samples on:



Specify on:



Left: Clear Storm Antique Mirrors **Below:** Bronze Storm Antique Mirrors



Standard Mirrors

Dependable mirrors made in the USA for over 60 years.



PRODUCT INFO

Glass: Made from mirror-quality clear glass.

Mirror Type: Conventional or Copper-Free

Edges: Clean Cut, Seamed, Flat Polished, or Pencil Polished

Fabrication Options: Holes, Cutouts, Notches

Safety Options: Tempering, Laminating, Vinyl Backing

Max Size: 100" x 144"

Thickness: 2.5mm (3/32") to 10mm (3/8")

Compliance: ASTM C1503, ASTM C1036

Warranty: 10 Years

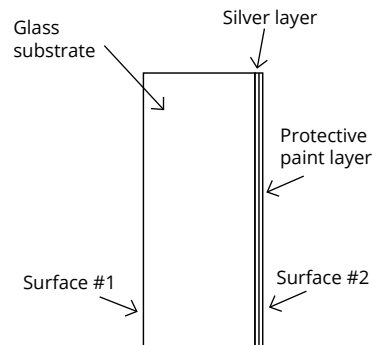

Order Samples on:



Specify on:



Clarity Mirrors

Super clear, low-iron mirrors for the sharpest, most accurate reflections.



PRODUCT INFO

Glass: Made with the highest quality, super-clear low-iron glass.

Edges: Clean Cut, Seamed, Flat Polished, or Pencil Polished

Fabrication Options: Holes, Cutouts, Notches

Safety Options: Tempering, Laminating

Max Size: 100" x 144"

Thickness: 3mm (1/8"), 4mm (5/32"), 5mm (3/16"), or 6mm (1/4")

Compliance: ASTM C1503 and ASTM C1036 (for annealed mirrors) or ASTM C1048 (for tempered mirrors)

Warranty: 10 Years

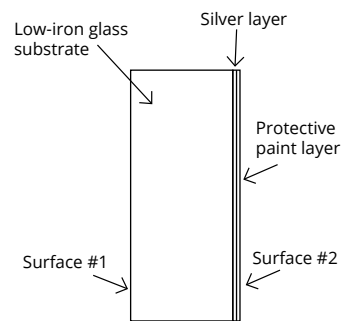

Order Samples on:



Specify on:

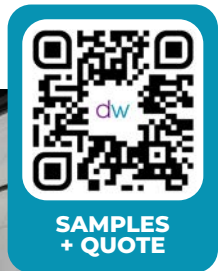

Backpainted Glass

Add a splash of color to brighten up any interior space.

Heat Cured

Up to 144 x 100"



PRODUCT INFO

Glass: Made with the highest quality, super-clear low-iron glass for vivid colors.

Colors: Choose from 15 standard colors or match any color within 1 Delta E using a spectrophotometer.



Finishes: Classic Glossy, ProSuede (matte, anti-glare finish), Metallic, or Pearlescent

Weight per SqFt (6mm): 3.2 lbs **Edges:** Flat Polished or Seamed

Protective Coat: We paint a protective coat on top of the color to help protect the color layer from damage during transit and installation.

Fabrication Options: Radius Corners, Holes, Cutouts, Notches

Safety Options: Tempering, Laminating

Max Size: 144" x 100" **Thickness:** 3mm (1/8") to 19mm (3/4")

Compliance: ASTM C1036, ASTM C1048 (when tempered), ASTM C1172 (when laminated)

Warranty: 5 Years



Order Samples on:



Specify on:

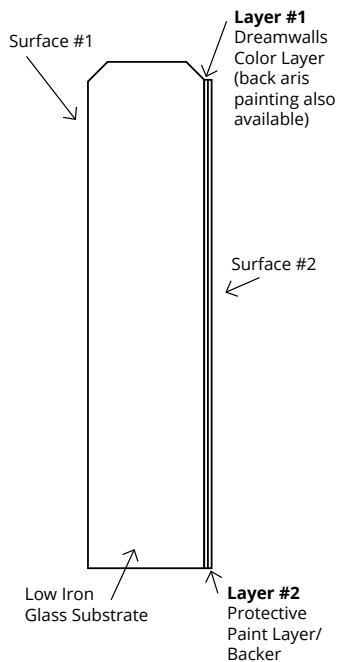

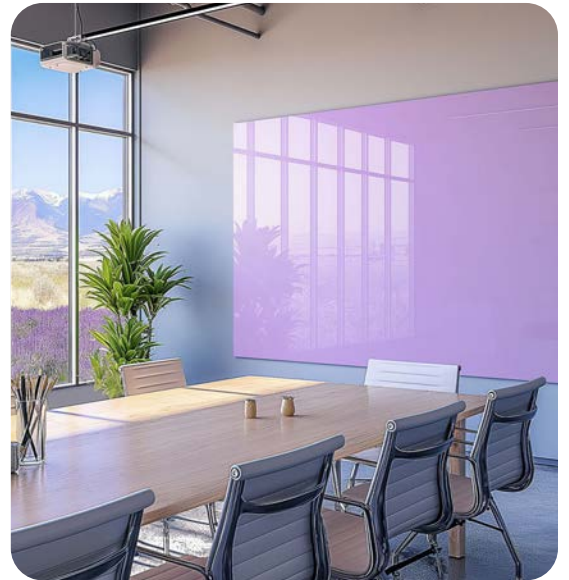

Laminated Glass

Let your imagination run wild. Go ultra custom with laminated glass.

Up to 84 x 140"



Laminated glass with printed gradient interlayer + backpainted glass

PRODUCT INFO

Substrate Options: Low-iron Glass, Standard Clear Glass, Tempered Glass, Backpainted Glass, Printed Glass, Antique Mirror, Shades Tinted Mirror, Etched Mirror, Clarity Mirror, Standard Mirror

Stock Interlayers: Clear EVA, Acid EVA, Matte EVA, White EVA, Black EVA, Clear SentryGlas, Translucent White SentryGlas

Custom Interlayers: Metallic Mesh, Fabrics, Magnetics, Organics, custom request.

Edges: Clean Cut, Seamed, or Flat Polished

Fabrication Options: Holes, Cutouts, Notches

Max Size: 84" x 140"

Thickness: up to 3" (edging up to 1")

Compliance: ASTM C1172, ANZI Z97.1

Warranty: 5 Years (10 Years for SentryGlas®)



Laminated glass with blue fabric interlayer

Order Samples on:



Specify on:



Laminated glass with printed pattern interlayer

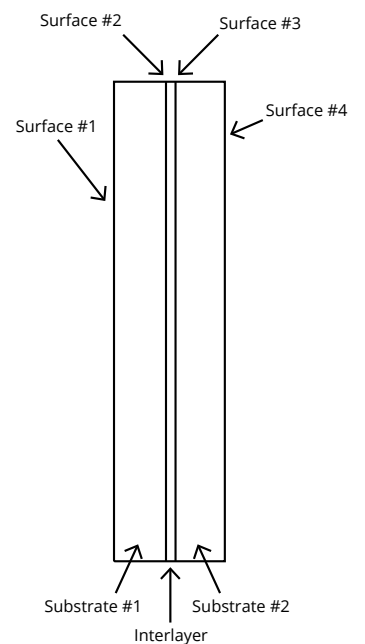

Laminated glass with translucent interlayer



Laminated glass railings



Laminated glass with printed wood interlayer



Laminated glass edge

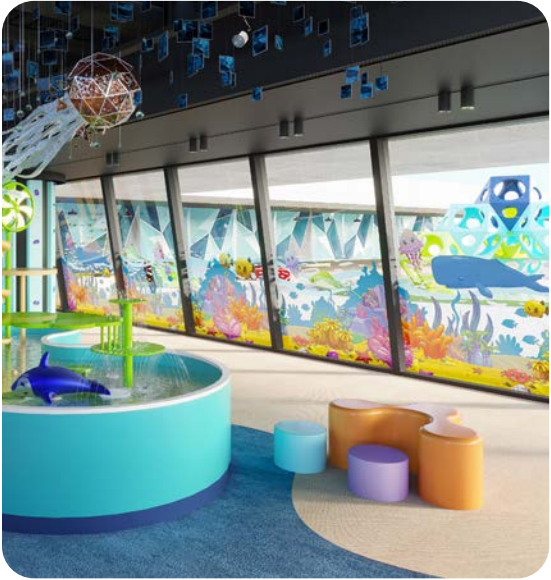

Laminated glass with custom printed graphics interlayer



Laminated glass with gold metallic mesh interlayer

Laminated Mirrors

The ultimate safety mirrors. Ideal for spaces with a high probability of strike or impact.

Up to 84 x 140"



PRODUCT INFO

Substrate Options: Clarity Mirror, Standard Mirror, Antique Mirror, Shades Tinted Mirror, Etched Mirror, Standard Clear Glass, Low-iron Glass, Tempered Glass

Interlayer Options: EVA, SentryGlas

Edges: Clean Cut, Seamed, or Flat Polished

Fabrication Options: Holes, Cutouts, Notches, Radius Corner

Max Size: 84" x 140"

Thickness: up to 3" (edging up to 1")

Compliance: ASTM C1172, ANZI Z97.1

Note: We do not laminate tempered mirror, however, we can laminate annealed mirrors to tempered clear or low-iron glass.

Warranty: 5 Years

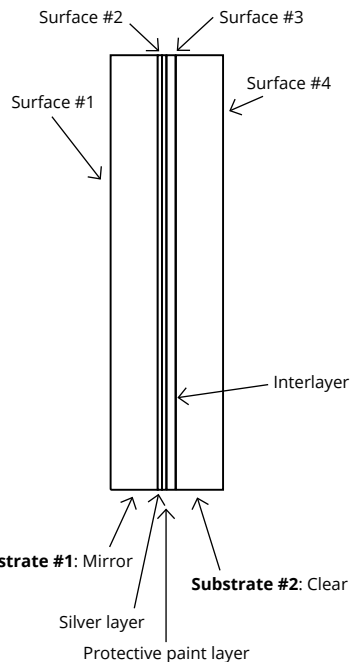
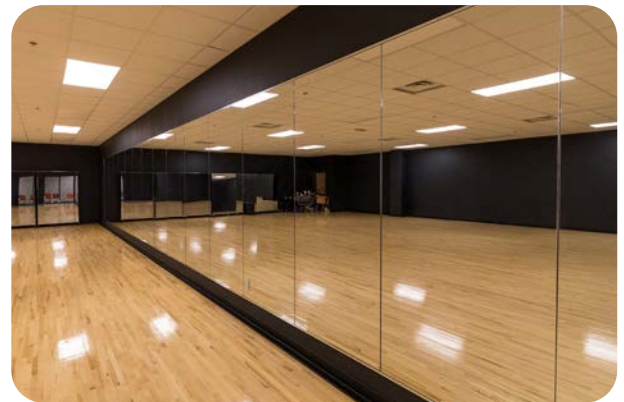

Specify on:



Tempered Mirrors

Beautiful safety mirrors done right - fabrication, tempering, and silvering all done in-house.

Up to 94 x 130"



PRODUCT INFO

Glass: Made from low-iron or mirror-quality clear glass.

Edges: Clean Cut, Seamed, Flat Polished

Fabrication Options: Holes, Cutouts

Min Size: 24" x 24"

Max Size: 94" x 130"

Thickness: 5mm (3/16"), 6mm (1/4")

Compliance: ASTM C1048, ANZI Z97.1, 16 CFR 1201 II (Federal Safety Standard)

Disclaimer: Tempered glass is used in manufacturing mirrors where safety is the paramount concern. Due to anomalies that are inherent in the tempering process, tempered mirror can not be held to the same quality standards of annealed mirror.

Surface blemishes that should be anticipated include scratches and rubs. Because the glass must be tempered prior to silvering, these blemishes can be encountered on both the face and silvered surfaces.

Silver overspray on the edges of tempered, polished edge mirrors is something that is unavoidable. This is the result of the process to produce this product. The glass must be edged prior to tempering. Silvering is the last step in the production process. Overspray on the edges is typical for this product.

Also inherent in tempered glass is an increased level of distortion. This distortion is due to the energy trapped in the glass by the tempering process. This creates a certain amount of bow or warp. The visual effect is further amplified by the application of the silver reflective coating in the mirroring process.

Alternative options include annealed mirror with safety backing or annealed mirror laminated to tempered clear or low-iron glass.

Warranty: 5 Years

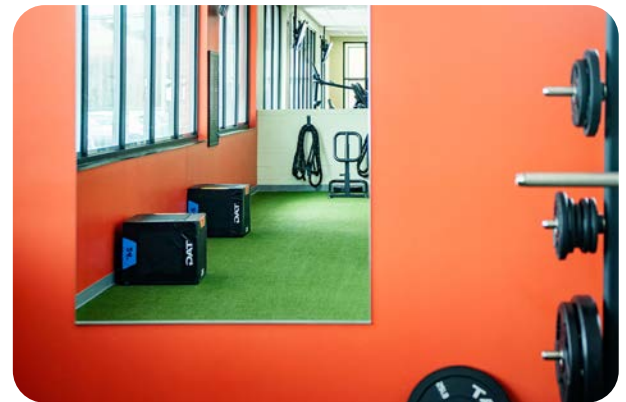

Specify on:

MasterSpec®

RIB | SpecLink

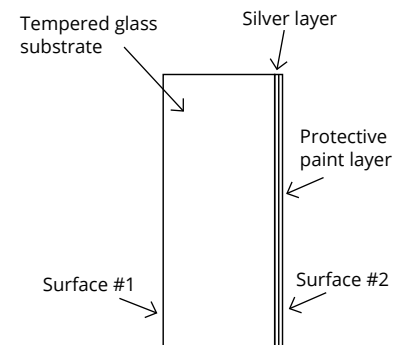



FIND OUR PRODUCTS ON



Headquarters & Manufacturing

301 Elkin Highway or PO Box 1570
North Wilkesboro, NC 28659
336.651.9300

Midwest Distribution

1705 Lafayette Rd
Indianapolis, IN 46222
317.464.0881

Texas Manufacturing

7553 State Hwy 75 South
Huntsville, TX 77340
936.291.7271



@dreamwallsglass